

ISO254

Precision, Powered, Three-Port Isolated PROGRAMMABLE GAIN AMPLIFIER

FEATURES

- **RATED**
1500Vrms Continuous
2500Vrms for One Minute
100% TESTED FOR PARTIAL DISCHARGE
- **PROGRAMMABLE GAINS OF**
1, 10, 100, 1000
- **HIGH IMR: 150dB at 50Hz**
- **LOW NONLINEARITY: $\pm 0.1\%$ max**
- **LOW INPUT BIAS CURRENT: 5nA max**
- **LOW INPUT OFFSET VOLTAGE:**
625 μ V max
- **INPUTS PROTECTED TO $\pm 40V$**
- **BIPOLAR OPERATION: $V_O = \pm 10V$**
- **PROTECTED INTERNAL SUPPLIES**
- **SYNCHRONIZATION CAPABILITY**
- **28-PIN PLASTIC DIP: 0.6" Wide**

APPLICATIONS

- **INDUSTRIAL PROCESS CONTROL**
Transducer Isolator, Thermocouple
Isolator, RTD Isolator, Pressure Bridge
Isolator, Flow Meter Isolator
- **POWER MONITORING**
- **MEDICAL INSTRUMENTATION**
- **ANALYTICAL MEASUREMENTS**
- **BIOMEDICAL MEASUREMENTS**
- **DATA ACQUISITION**
- **TEST EQUIPMENT**
- **GROUND LOOP ELIMINATION**

DESCRIPTION

ISO254P is a precision three-port isolated programmable gain instrumentation amplifier incorporating a novel duty cycle modulation-demodulation technique and has excellent accuracy. Internal input protection can withstand up to $\pm 40V$ input differential without damage. The signal is transmitted digitally across a 2pF differential capacitive barrier. With digital modulation the barrier characteristics do not affect signal integrity. This results in excellent reliability and good high frequency transient immunity across the barrier. The DC/DC converter, amplifier and barrier capacitors are housed in a plastic DIP.

This amplifier is easy to use as no external components are required. A power supply range of 11V to 18V and low quiescent current make this amplifier ideal for a wide range of applications.

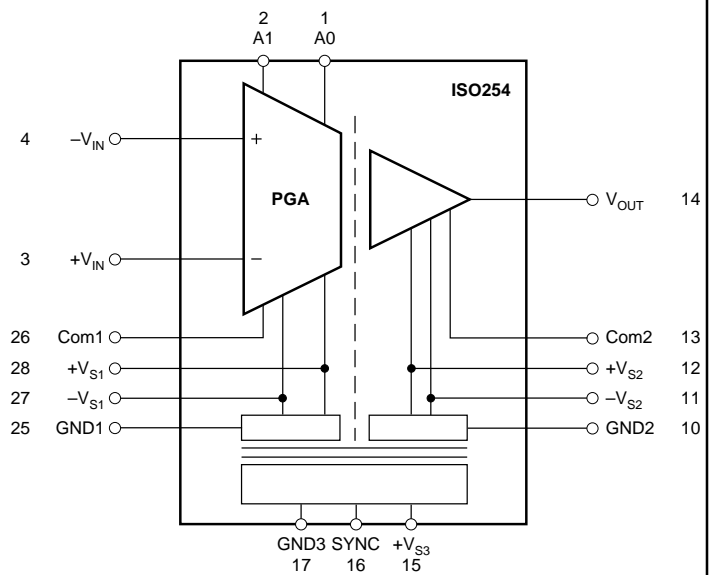

SPECIFICATIONS

At $T_A = +25^\circ\text{C}$, $+V_{S3} = 15\text{V}$, and 220nf capacitors on all generated supplies, unless otherwise noted.

PARAMETER	CONDITIONS	ISO254P			UNITS
		MIN	TYP	MAX	
ISOLATION Voltage Rated Continuous: AC 100% Test (AC 50Hz) Rated One Min Isolation-Mode Rejection DC AC 50Hz Barrier Impedance Leakage Current	T_{MIN} to T_{MAX} 1s; Partial Discharge $\leq 5\text{pC}$ 1500Vrms	1500 2500 2500	160 150 $10^{14} \parallel 13$ 1.4	2	Vrms Vrms Vrms dB dB $\Omega \parallel \text{pF}$ μArms
GAIN Gain Error Gain vs Temperature Nonlinearity	G = 1 G = 10 G = 100 G = 1000 G = 1 G = 10 G = 100 G = 1000 G = 1 G = 10 G = 100 G = 1000		0.15 0.15 0.15 0.2 ± 15 ± 15 ± 15 ± 15 ± 0.01 ± 0.01 0.01 ± 0.01	± 0.3 ± 0.3 ± 0.102 ± 0.104	% % ppm/ $^\circ\text{C}$ ppm/ $^\circ\text{C}$ ppm/ $^\circ\text{C}$ ppm/ $^\circ\text{C}$ % %
INPUT OFFSET VOLTAGE Initial Offset vs Temperature CMRR vs Supply		75	$\pm \left(4 + \frac{510}{G} \right)$ 160 1	$\pm(1+101/G)$	mV $\mu\text{V}/^\circ\text{C}$ dB mV/V
INPUT Voltage Range Bias Current vs Temperature Offset Current vs Temperature		± 10	± 8 ± 8	± 5 ± 2	V nA pA/ $^\circ\text{C}$ nA pA/ $^\circ\text{C}$
OUTPUT Voltage Range Current Drive Capacitive Load Drive Ripple Voltage		± 10 ± 5	0.1 25		V mA μF mVp-p
FREQUENCY RESPONSE Small Signal Bandwidth Slew Rate Settling Time, 0.1%	G = 1 G = 10 G = 100 G = 1000 G = 1 G = 10 G = 100 G = 1000		50 30 6 1 0.35 80 380 490 1650		kHz kHz kHz kHz V/ μs μs μs μs μs
POWER SUPPLIES Rated Voltage Voltage Range Quiescent Current Rated Output Voltage Load Regulation Line Regulation SYNC Frequency Output Voltage Ripple	No Load 50mA Load On Two Supplies	11 30 13 12	15 40 14.5 13.2 35 1 50	18 55 16 1.4	V V mA V V mV/mA V/V MHz mV
TEMPERATURE RANGE Operating Storage θ_{JA}		-40 -40	80	85 125	$^\circ\text{C}$ $^\circ\text{C}$ $^\circ\text{C}/\text{W}$

ABSOLUTE MAXIMUM RATINGS

Supply Voltage	18V
V_{IN} , Analog Input Voltage Range	$\pm 40V$
Com 1 to Gnd 1	$\pm 1V$
Com 2 to Gnd 2	$\pm 1V$
Continuous Isolation Voltage	1500Vrms
.....	2500Vrms one min
IMV, dv/dt	20kV/ μ s
Junction Temperature	150°C
Storage Temperature	-40°C to +85°C
Lead Temperature (soldering, 10s)	+300°C
Output Short Duration	Continuous to Common

ELECTROSTATIC DISCHARGE SENSITIVITY

Any integrated circuit can be damaged by ESD. Burr-Brown recommends that all integrated circuits be handled with appropriate precautions. Failure to observe proper handling and installation procedures can cause damage.

ESD damage can range from subtle performance degradation to complete device failure. Precision integrated circuits may be more susceptible to damage because very small parametric changes could cause the device not to meet published specifications.

ORDERING INFORMATION

MODEL	PACKAGE
ISO254P	28-Pin Plastic DIP

PIN CONFIGURATION

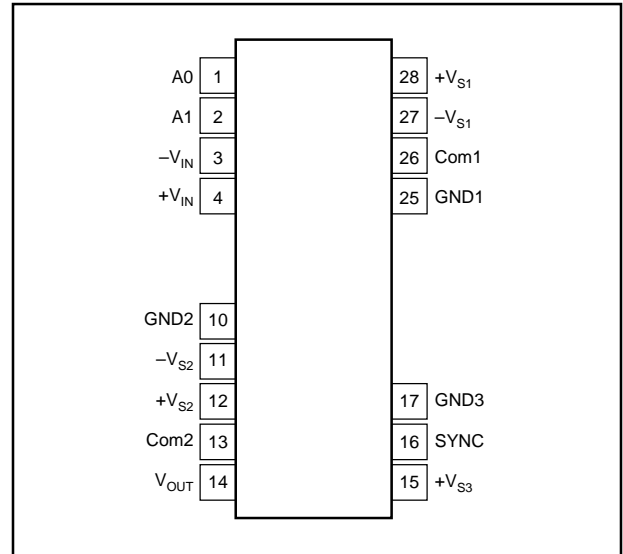

PACKAGE INFORMATION

MODEL	PACKAGE	PACKAGE DRAWING NUMBER ⁽¹⁾
ISO254P	28-Pin Plastic DIP	335

NOTE: (1) For detailed drawing and dimension table, please see end of data sheet, or Appendix D of Burr-Brown IC Data Book.

TYPICAL PERFORMANCE CURVES

At $T_A = +25^\circ\text{C}$, $+V_{S3} = 15V$, and 220nf capacitors on all generated supplies, unless otherwise noted.

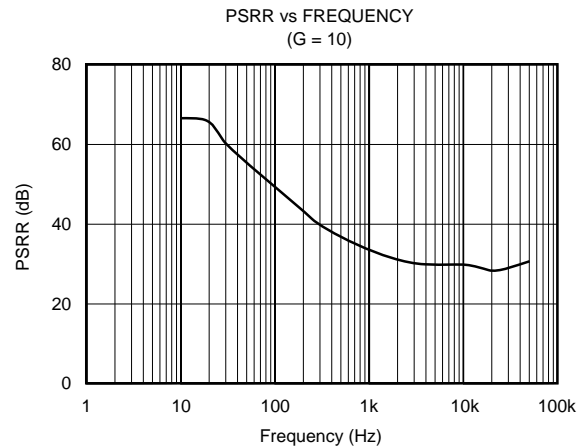
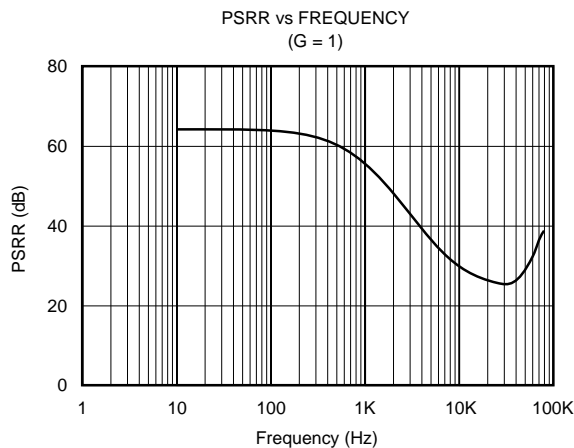

The information provided herein is believed to be reliable; however, BURR-BROWN assumes no responsibility for inaccuracies or omissions. BURR-BROWN assumes no responsibility for the use of this information, and all use of such information shall be entirely at the user's own risk. Prices and specifications are subject to change without notice. No patent rights or licenses to any of the circuits described herein are implied or granted to any third party. BURR-BROWN does not authorize or warrant any BURR-BROWN product for use in life support devices and/or systems.

TYPICAL PERFORMANCE CURVES (CONT)

At $T_A = +25^\circ\text{C}$, $+V_{S3} = 15\text{V}$, and 220nf capacitors on all generated supplies, unless otherwise noted.

ISOLATION LEAKAGE CURRENT vs FREQUENCY
($V = 240\text{Vrms}$)

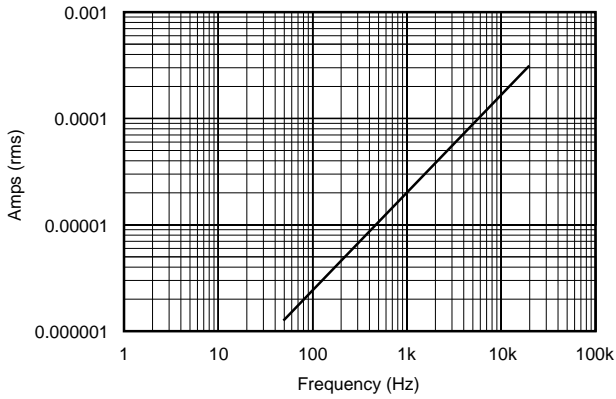

IMR vs FREQUENCY

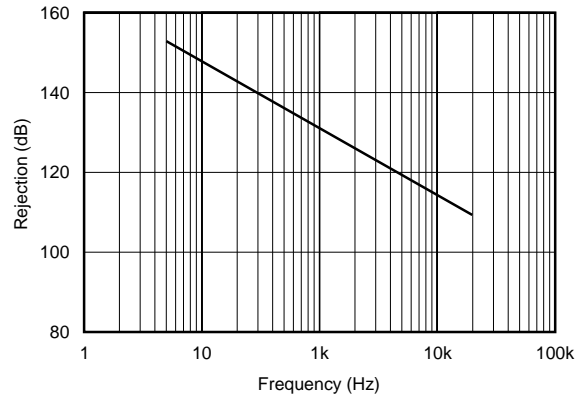

SIGNAL RESPONSE vs CARRIER FREQUENCY

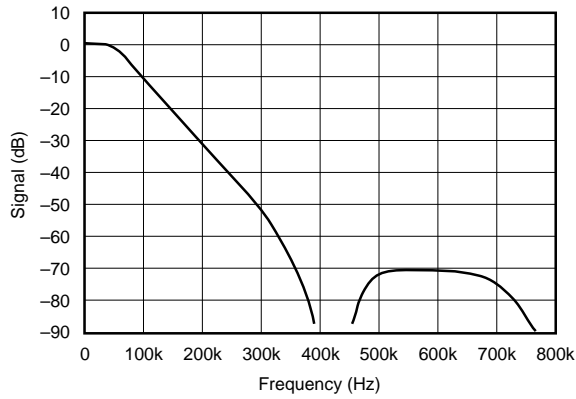

SINE RESPONSE
($f = 1\text{kHz}$, $G = 1$)

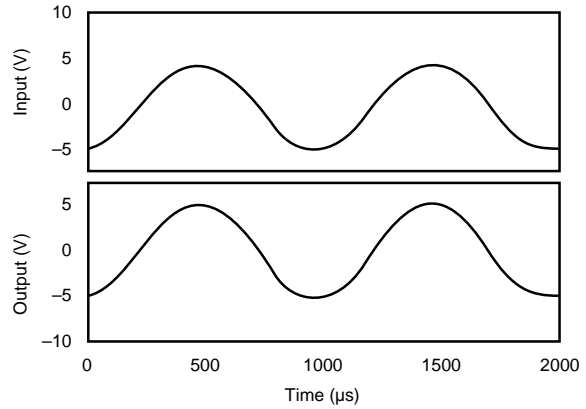

SINE RESPONSE
($f = 10\text{kHz}$, $G = 1$)

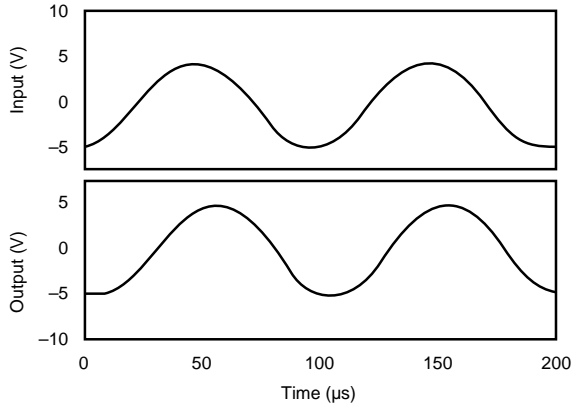

PULSE RESPONSE
($f = 1\text{kHz}$, $G = 1$)

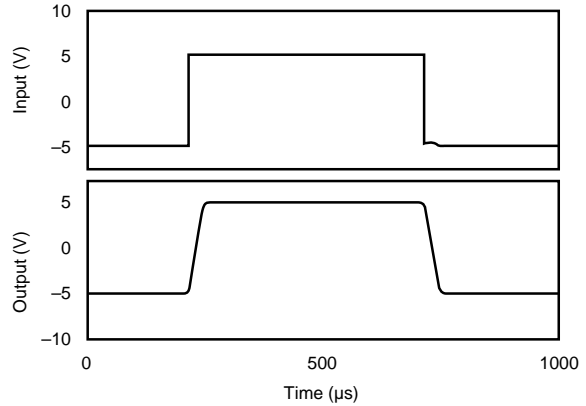

TYPICAL PERFORMANCE CURVES (CONT)

At $T_A = +25^\circ\text{C}$, $+V_{S3} = 15\text{V}$, and 220nf capacitors on all generated supplies, unless otherwise noted.

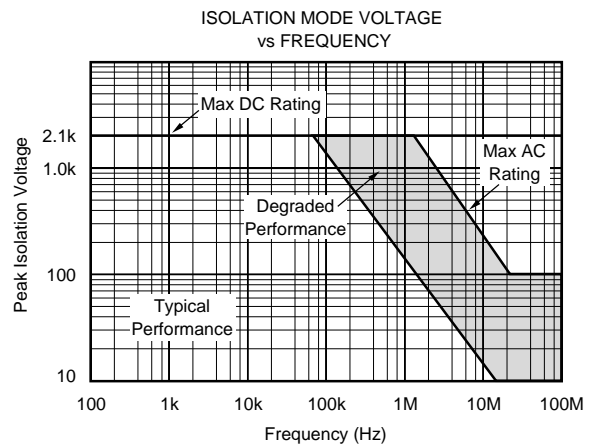
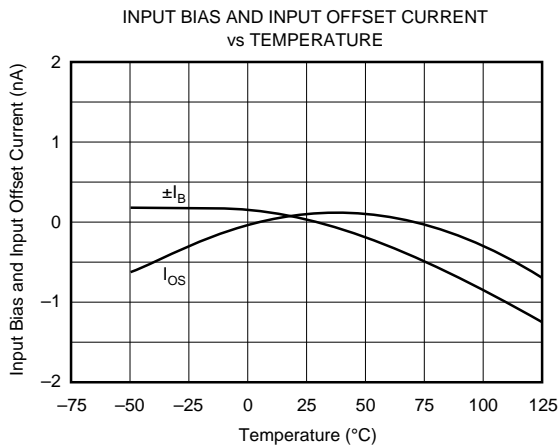
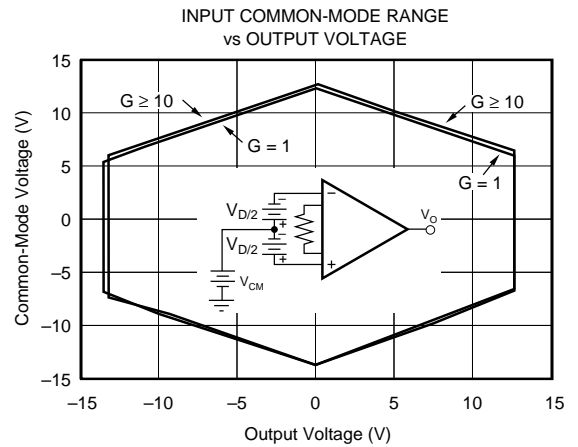
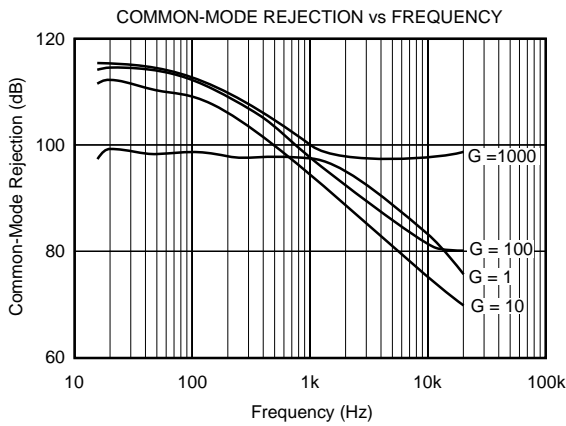
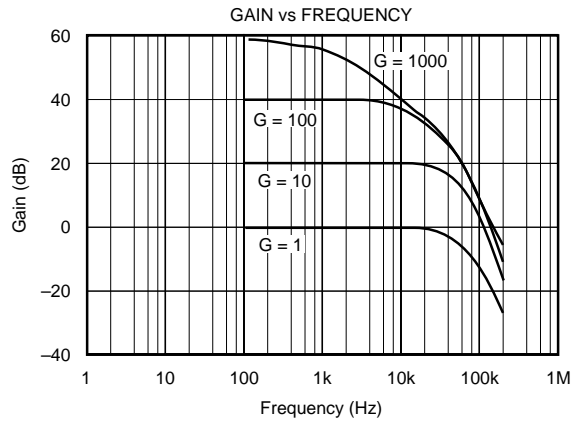
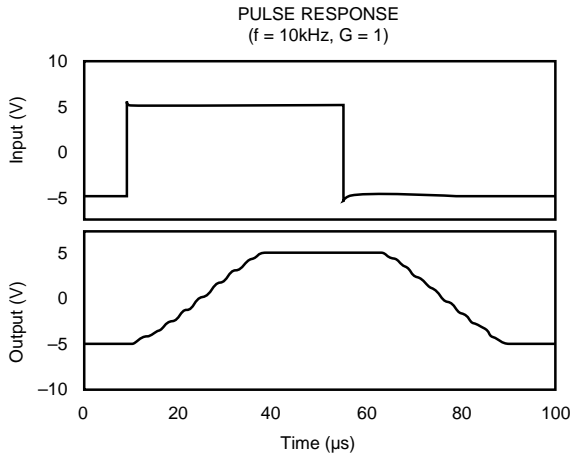

BASIC OPERATION

ISO254P is a precision, powered, three-port isolated programmable-gain amplifier. The input and output sections are galvanically isolated by matched and EMI shielded 1pF capacitors built into the plastic package. The DC/DC converter input is also galvanically isolated from both the input and output supplies.

SIGNAL AND POWER CONNECTIONS

Figure 1 shows proper power and signal connections. The power supply input pin $+V_{S3}$ should be bypassed with a 2.2 μ F tantalum capacitor and the outputs V_{S1} and V_{S2} with 220nf ceramic capacitors located as close to the amplifier as possible. All ground connections should be run independently to a common point if possible. Signal Common on both input and output sections provide a high-impedance point for sensing signal ground in noisy applications. Com1 and Com2 must have a path to ground for bias current return and should be maintained within $\pm 1V$ of Gnd.

INPUT COMMON-MODE RANGE

The linear common-mode range of the input circuitry of the ISO254P is approximately $\pm 12.7V$ (or 2.3V from the power supplies). As the output voltage increases, however, the linear input range will be limited by the output voltage swing of the internal amplifiers. Thus, the linear common-mode range is related to the output voltage of the complete input amplifier—see performance curves “Input Common-Mode Range vs Output Voltage.”

A combination of common-mode and differential input voltage can cause the output voltage of the internal amplifiers to saturate. For applications where input common-mode range must be maximized, limit the output voltage swing by selecting a lower gain of the programmable-gain input.

Input-overload can produce an output voltage that appears normal. For example, an input voltage of +20V on one input and +40V on the other input will exceed the linear common-mode range of both input amplifiers. Since both input amplifiers are saturated to nearly the same output voltage limit, the difference voltage measured by the output amplifier will be near zero. The output of the programmable-gain amplifier will be near 0V even though both inputs are overloaded.

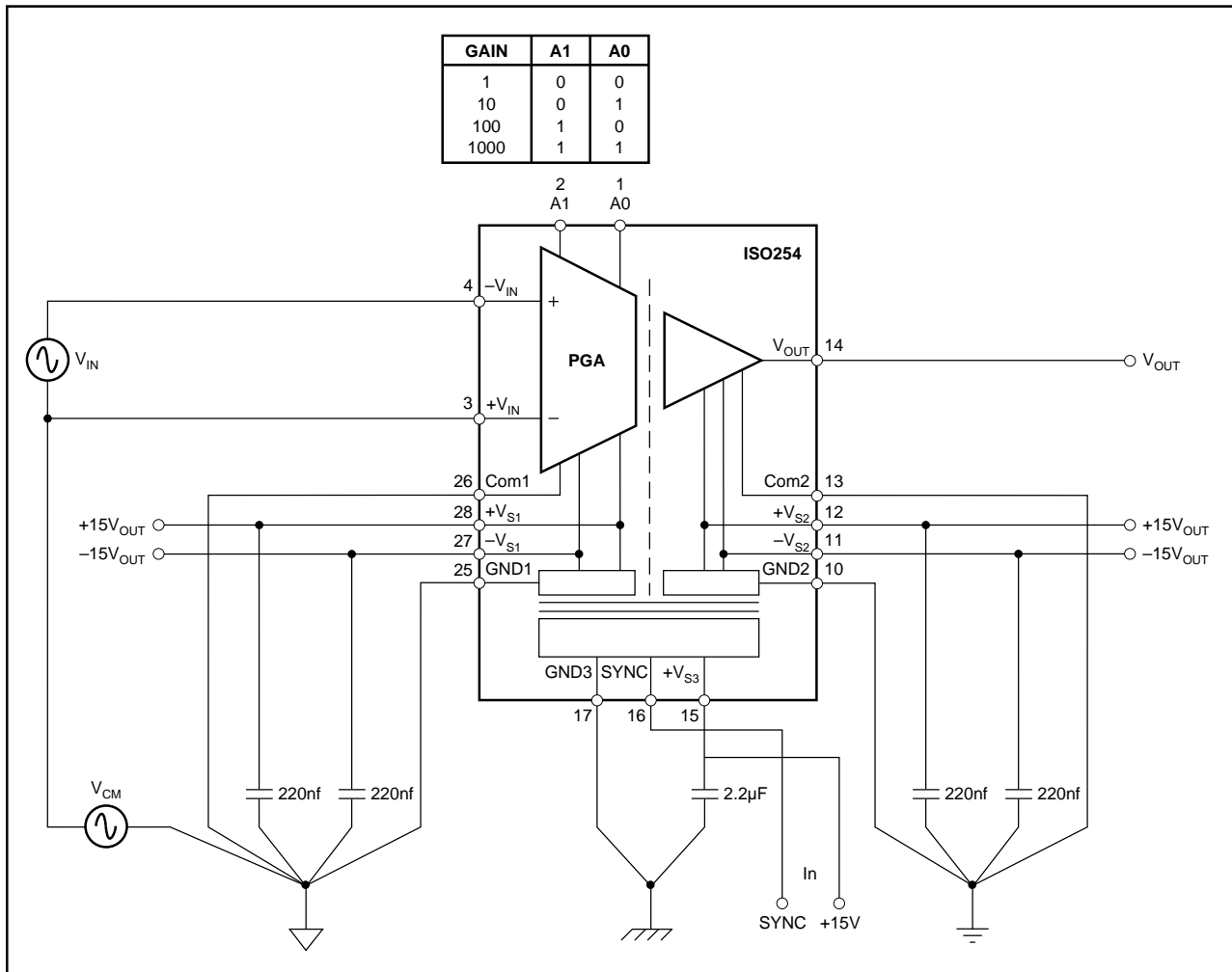

FIGURE 1. Basic Connections.

INPUT PROTECTION

The inputs of the programmable-gain amplifiers are individually protected for voltages up to $\pm 40\text{V}$. Internal circuitry on each input provides low series impedance under normal signal conditions. If the input is overloaded, the protection circuitry limits the input current to a safe value (approximately 1.5mA). The inputs are protected even if no power supply is present.

DC/DC CONVERTER

ISO254P provides a reliable solution to the need for integral power. The high isolation rating being achieved by careful design and attention to the physical construction of the transformer. In addition to the high dielectric strength a low leakage coating increases the isolation voltage range. The soft start oscillator/driver design eliminates high inrush currents during turn-on. Input current sensing protects both the converter and the load from possible thermal damage during a fault condition. The DC/DC converter is synchronized to the amplifier and when multiple ISO254P's are used, each channel can be synchronized via the SYNC pin.

The DC/DC converter consists of a free-running oscillator, control and switch driver circuitry, MOSFET switches, a transformer, rectifier diodes and filter capacitors all contained within the ISO254P package. The control circuitry consists of current limiting, soft start and synchronization features. In instances where several ISO254P's are used in a system, beat frequencies developed between the ISO254P's are a potential source of low frequency noise in the supply and ground paths. This noise may couple into the signal path and can be avoided by synchronizing the individual ISO254P's together by tying the SYNC pins together or using the circuit in Figure 2 to drive the SYNC pins from an external source.

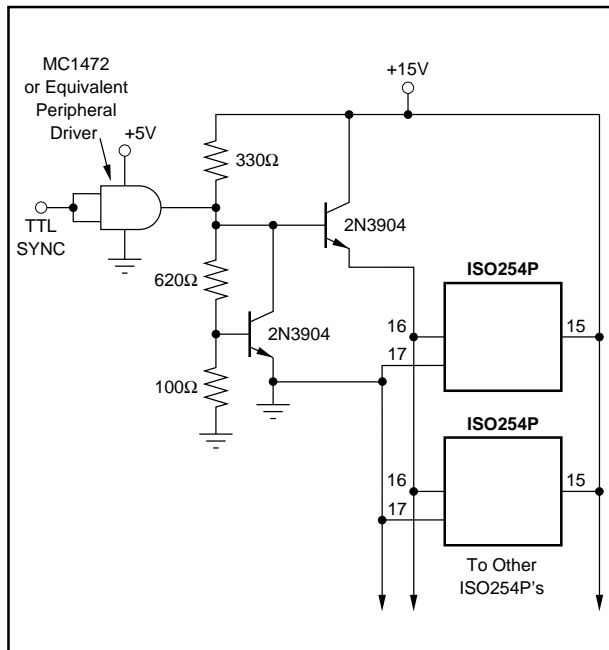

FIGURE 2. External SYNC drive.

When connecting up to eight ISO254P's without a driver the unit with the highest natural frequency will determine the synchronized running frequency. The SYNC pin is sensitive to capacitive loading: 150pf or less is recommended. If unused, the SYNC pin should be left open. Avoid shorting the SYNC pin directly to ground or supply potentials; otherwise damage may result.

Soft start circuitry protects the MOSFET switches during startup. This is accomplished by holding the gate-to-source voltage of both MOSFET switches low until the free-running oscillator is fully operational. In addition, soft start circuitry and input current sensing also protects the switches. This current limiting keeps the MOSFET switches operating in their safe operating area under fault conditions or excessive loads. When either of these conditions occur, the peak input current exceeds a safe limit. The result is an approximate 5% duty cycle, 300 μs drive period to the MOSFET switches. This protects the internal MOSFET switches as well as the external load from any thermal damage. When the fault or excessive load is removed, the converter resumes normal operation. A delay period of approximately 50 μs incorporated in the current sensing circuitry allows the output filter capacitors to fully charge after a fault is removed. This delay period corresponds to a filter capacitance of no more than 1 μf at either of the output pins. This provides full protection of the MOSFET switches and also sufficiently filters the output ripple voltage. The current sensing circuitry is designed to provide thermal protection for the MOSFET switches over the operating temperature range as well. When these conditions are exceeded, the unit will go into its shutdown mode.

OUTPUT CURRENT RATINGS

The total current which can be drawn from each output supply on the ISO254P is a function of the total power drawn from all outputs. For example if three outputs are not used then maximum current can be drawn from one output. In all cases, the total maximum current that can be drawn from any combination of outputs is:

$$|I_{1+}| + |I_{1-}| + |I_{2+}| + |I_{2-}| \leq 50\text{mA}$$

+V_{S3}, GND3

The waveform of the ground return current is an 800kHz sawtooth. A capacitor between +V_{S3} and GND3 provides a bypass for the AC portion of this current. The power should never be instantaneously interrupted to the ISO254P (i.e., a break in the line to +V_{S3} either by accidental or switch means.) Normal power down of the +V_{S3} supply is not considered instantaneous. Should a rapid break in input power occur the internal transformers voltage will rapidly rise to maintain current flow and may cause internal damage to the ISO254P.

SYNCHRONIZED OPERATION

ISO254P can be synchronized to an external signal source. This capability is useful in eliminating troublesome beat frequencies in multi-channel systems and in rejecting AC signals and their harmonics. To use this feature, tie all sync pins together or apply an external signal to the SYNC pin. ISO254P can be synchronized to an external oscillator over the range 1-1.4MHz (this corresponds to a modulation frequency of 500kHz to 700kHz as SYNC is internally divided by 2).

CARRIER FREQUENCY CONSIDERATIONS

ISO254P amplifiers transmit the signal across the ISO-barrier by a duty-cycle modulation technique. This system works like any linear amplifier for input signals having frequencies below one half the carrier frequency, f_C . For signal frequencies above $f_C/2$, the behavior becomes more complex. The “Signal Response vs Carrier Frequency” performance curve describes this behavior graphically. The upper curve illustrates the response for input signals varying from DC to $f_C/2$. At input frequencies at or above $f_C/2$, the device generates an output signal component that varies in both amplitude and frequency, as shown by the lower curve. The lower horizontal scale shows the periodic variation in the frequency of the output component. Note that at the carrier frequency and its harmonics, both the frequency and amplitude of the response go to zero. These characteristics can be exploited in certain applications.

It should be noted that for the ISO254P, the carrier frequency is nominally 400kHz and the -3dB point of the amplifier is 50kHz. Spurious signals at the output are not significant under these circumstances unless the input signal contains significant components above 200kHz.

When periodic noise from external sources such as system clocks and DC/DC converters are a problem, ISO254P can be used to reject this noise. The amplifier can be synchronized to an external frequency source, f_{EXT} , placing the amplifier response curve at one of the frequency and amplitude nulls indicated in the “Signal Response vs Carrier Frequency” performance curve.

ISOLATION MODE VOLTAGE

Isolation Mode Voltage (IMV) is the voltage appearing between isolated grounds Gnd1 and Gnd2. The IMV can induce errors at the output as indicated by the plots of IMV vs Frequency. It should be noted that if the IMV frequency exceeds $f_C/2$, the output will display spurious outputs in a manner similar to that described above, and the amplifier response will be identical to that shown in the “Signal Response vs Carrier Frequency” performance curve. This occurs because IMV-induced errors behave like input-referred error signals. To predict the total IMR, divide the isolation voltage by the IMR shown in “IMR vs Frequency” performance curve and compute the amplifier response to this input-referred error signal from the data given in the

“Signal Response vs Carrier Frequency” performance curve. Due to effects of very high-frequency signals, typical IMV performance can be achieved only when dV/dT of the isolation mode voltage falls below $1000\text{V}/\mu\text{s}$. For convenience, this is plotted in the typical performance curves for the ISO254P as a function of voltage and frequency for sinusoidal voltages. When dV/dT exceeds $1000\text{V}/\mu\text{s}$ but falls below $20\text{kV}/\mu\text{s}$, performance may be degraded. At rates of change above $20\text{kV}/\mu\text{s}$, the amplifier may be damaged, but the barrier retains its full integrity. Lowering the power supply voltage below 15V may decrease the dV/dT to $500\text{V}/\mu\text{s}$ for typical performance, but the maximum dV/dT of $20\text{kV}/\mu\text{s}$ remains unchanged.

Leakage current is determined solely by the impedance of the barrier and transformer capacitance and is plotted in the “Isolation Leakage Current vs Frequency” curve.

ISOLATION VOLTAGE RATINGS

Because a long-term test is impractical in a manufacturing situation, the generally accepted practice is to perform a production test at a higher voltage for some shorter time. The relationship between actual test voltage and the continuous derated maximum specification is an important one.

Historically, Burr-Brown has chosen a deliberately conservative one: $V_{\text{TEST}} = (2 \times \text{ACrms continuous rating}) + 1000\text{V}$ for 10 seconds, followed by a test at rated ACrms voltage for one minute. This choice was appropriate for conditions where system transients are not well defined.

Recent improvements in high-voltage stress testing have produced a more meaningful test for determining maximum permissible voltage ratings, and Burr-Brown has chosen to apply this new technology in the manufacture and testing of the ISO254P.

Partial Discharge

When an insulation defect such as a void occurs within an insulation system, the defect will display localized corona or ionization during exposure to high-voltage stress. This ionization requires a higher applied voltage to start the discharge and lower voltage to maintain it or extinguish it once started. The higher start voltage is known as the inception voltage, while the extinction voltage is that level of voltage stress at which the discharge ceases. Just as the total insulation system has an inception voltage, so do the individual voids. A voltage will build up across a void until its inception voltage is reached, at which point the void will ionize, effectively shorting itself out. This action redistributes electrical charge within the dielectric and is known as partial discharge. If, as is the case with AC, the applied voltage gradient across the device continues to rise, another partial discharge cycle begins. The importance of this phenomenon is that, if the discharge does not occur, the insulation system retains its integrity. If the discharge begins, and is allowed to continue, the action of the ions and electrons within the defect will eventually degrade any organic insulation system in which they occur. The measure-

ment of partial discharge is still useful in rating the devices and providing quality control of the manufacturing process. The inception voltage for these voids tends to be constant, so that the measurement of total charge being redistributed within the dielectric is a very good indicator of the size of the voids and their likelihood of becoming an incipient failure. The bulk inception voltage, on the other hand, varies with the insulation system, and the number of ionization defects and directly establishes the absolute maximum voltage (transient) that can be applied across the test device before destructive partial discharge can begin. Measuring the bulk extinction voltage provides a lower, more conservative voltage from which to derive a safe continuous rating. In production, measuring at a level somewhat below the expected inception voltage and then de-rating by a factor related to expectations about system transients is an accepted practice.

Partial Discharge Testing

Not only does this test method provide far more qualitative information about stress-withstand levels than did previous stress tests, but it provides quantitative measurements from which quality assurance and control measures can be based. Tests similar to this test have been used by some manufacturers, such as those of high-voltage power distribution

equipment, for some time, but they employed a simple measurement of RF noise to detect ionization. This method was not quantitative with regard to energy of the discharge, and was not sensitive enough for small components such as isolation amplifiers. Now, however, manufacturers of HV test equipment have developed means to quantify partial discharge. VDE, the national standards group in Germany and an acknowledged leader in high-voltage test standards, has developed a standard test method to apply this powerful technique. Use of partial discharge testing is an improved method for measuring the integrity of an isolation barrier.

To accommodate poorly-defined transients, the part under test is exposed to voltage that is 1.6 times the continuous-rated voltage and must display less than or equal to 5pC partial discharge level in a 100% production test.

APPLICATIONS

The ISO254P isolation amplifiers are used in three categories of applications:

- Accurate isolation of signals from high voltage ground potentials
- Accurate isolation of signals from severe ground noise and
- Fault protection from high voltages in analog measurements

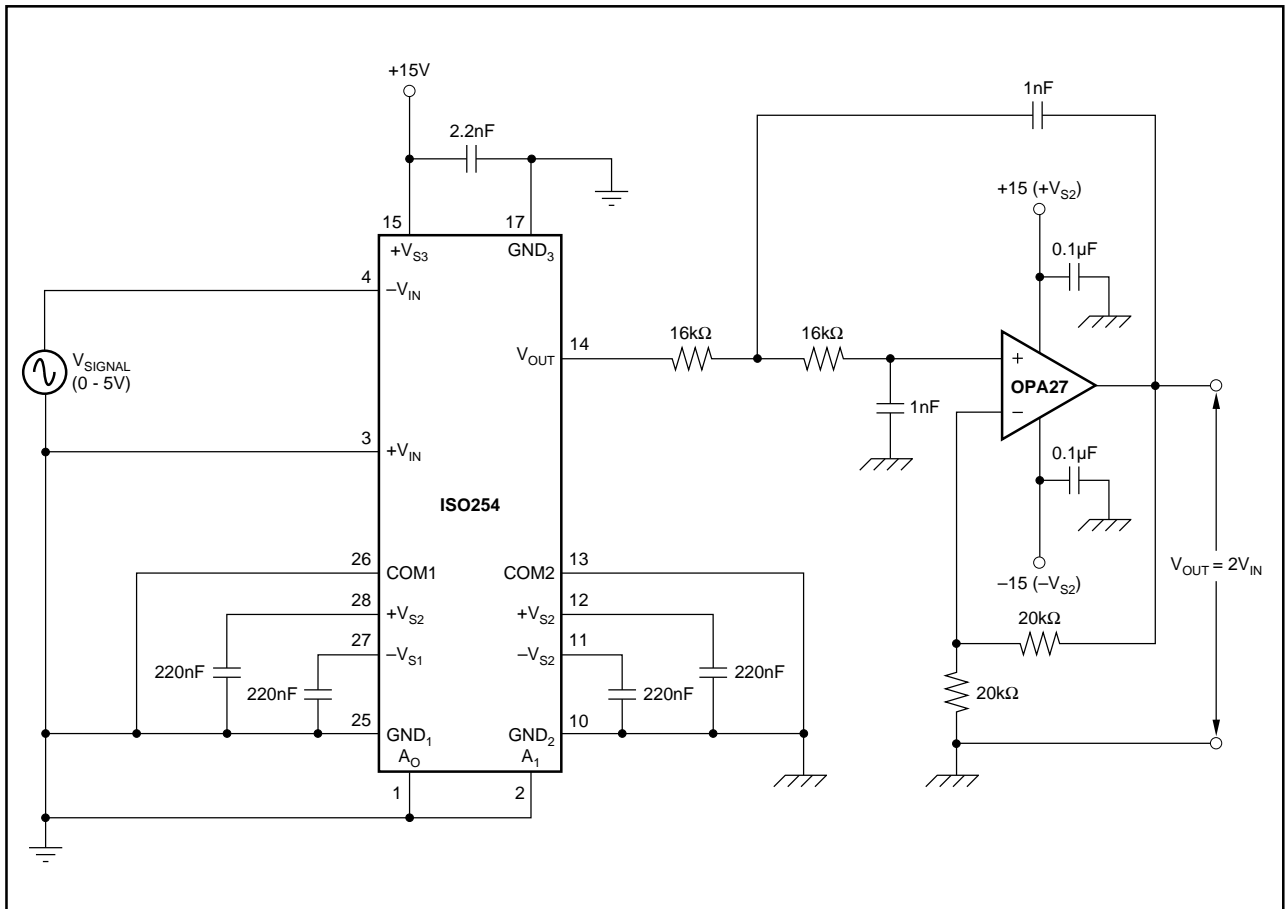

FIGURE 3. Noise Reduction in Data Acquisition System.